

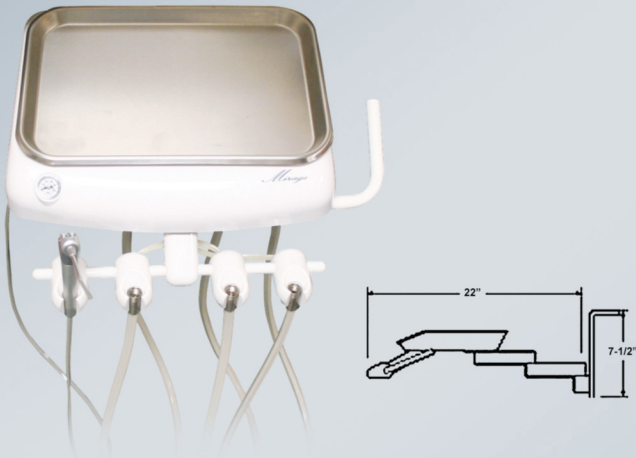

Mirage

Wall / Cabinet Mounted Systems



MR-4000 Cabinet Mounted Rear Delivery Unit

Standard Features

- 3 way syringe with quick change autoclavable tip
- Master ON/OFF toggle with indicator
- Air / water pressure adjustment for each handpiece
- Easy to read pressure gauge
- Air coolant flow adjustment
- Non-retracting water coolant adjustment and purge
- Plated brass valving for long life
- Asepsis handpiece tubing
- Slide-out mount
- Soft-touch variable speed foot control
- Utility center assembly (less housing)
- 7' umbilical tubing
- Packing dimensions: 18" x 13" x 9" / 151 lbs.

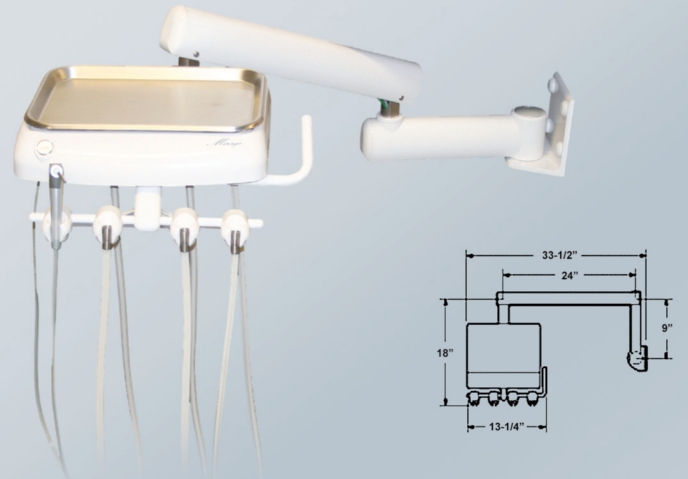

MS-3000 Cabinet Mounted Side Delivery Unit

Standard Features

- Asepsis designed automatic selection for 3 handpieces
- 3 way syringe with quick change autoclavable tip
- Master ON/OFF toggle with indicator
- Air / water pressure adjustment for each handpiece
- Easy to read pressure gauge (protected under cover)
- Air coolant flow adjustment
- Non-retracting water coolant adjustment and purge
- Plated brass valving for long life
- Asepsis handpiece tubing
- Asepsis flex arm, with 9" rigid arm, with pneumatic brake, 39" reach, 19" vertical travel
- 2" diameter wall mount bracket
- Soft-touch variable speed foot control
- Utility center assembly (less housing)
- 7' umbilical tubing
- Packing dimensions: 55" x 26" x 21" / 60 lbs.

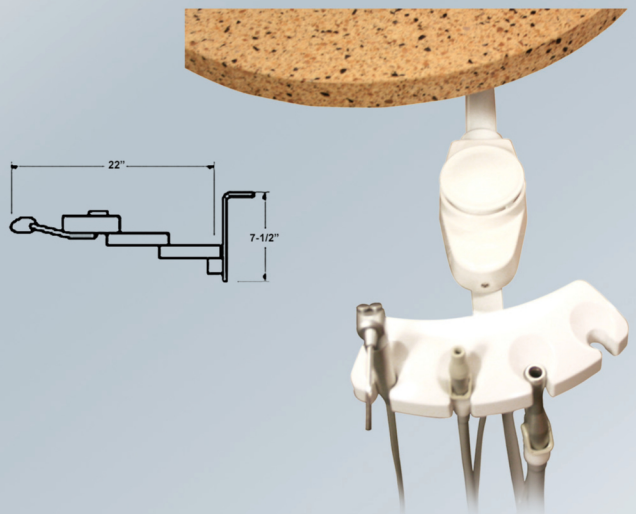

MVP-5000 Cabinet Mounted Vacuum Package

Standard Features

- 3 way syringe with quick change autoclavable tip
- Vacuum canister with removable screen
- 1 autoclavable HVE and saliva ejector valve with tubing
- 7' umbilical tubing
- Packing dimensions: 16" x 12" x 5" / 10 lbs.